



# **RGC-IR**

## **Remote Gas Calibrator**

### **for IR400**



The information and technical data disclosed in this document may be used and disseminated only for the purposes and to the extent specifically authorized in writing by General Monitors.

**Instruction Manual**

**11-09**

General Monitors reserves the right to change published specifications and designs without prior notice.



**Part No.**  
**Revision**

**MANRGC-IR**  
**B/11-09**

This page intentionally left blank

# Table of Contents

<b>TABLE OF FIGURES .....</b>	<b>IV</b>
<b>ABOUT THIS MANUAL .....</b>	<b>1</b>
Format Conventions.....	1
Notes, Cautions, and Warnings .....	1
Contacting Customer Support.....	1
<b>1.0 BEFORE INSTALLATION.....</b>	<b>2</b>
1.1 System Integrity Verification .....	2
1.2 Commissioning Safety Systems .....	2
1.3 Periodic Testing and Calibration of Field Devices .....	2
1.4 Special Warning .....	3
<b>2.0 INTRODUCTION .....</b>	<b>4</b>
2.1 Description .....	4
<b>3.0 INSTALLATION.....</b>	<b>5</b>
3.1 Installation Options.....	6
3.2 Sensor Calibration using RGC-IR .....	7
<b>4.0 CUSTOMER SUPPORT .....</b>	<b>8</b>
4.1 General Monitors' Offices .....	8
4.2 Other Sources of Help .....	8
<b>5.0 APPENDIX.....</b>	<b>9</b>
5.1 Warranty.....	9
<b>6.0 SPECIFICATIONS.....</b>	<b>10</b>
6.1 Functional Specifications .....	10
6.2 Environmental Specifications.....	10
6.3 Mechanical Specifications.....	10
6.4 RGC-IR Dimensions and Outline Drawing.....	10

## Table of Figures

Figure 1: RGC (P/N 32541-1).....	4
Figure 2: Gas Cylinder and Regulator.....	5
Figure 3: IR4000S with IR400 and RGC-IR (P/N 32541-1) for Manual Gassing.....	6
Figure 4: RGC (32541-1) with IR4000S/M Dimensions and Outline Drawing.....	10

## About This Manual

This manual provides instructions for installing, operating, and maintaining the General Monitors, Inc. (GM) Remote Gas Calibrator for IR400 (RGC-IR). The intended audience includes installation personnel, field service technicians, and other technical staff involved in installing and using the RGC-IR.

### Format Conventions

Several format conventions are used throughout this manual for Notes, Cautions, Warnings, User Menus, and Modbus notations. These conventions are described below.

### Notes, Cautions, and Warnings

---

**NOTE:** Notes provide supplementary details such as exception conditions, alternate methods for a task, time saving tips, and references to related information.

---



**CAUTION:** These notices describe precautions to prevent hazardous conditions that may damage the equipment.



**WARNING:** These notices describe precautions to prevent hazardous conditions that may cause injury to people working with the equipment.

### Contacting Customer Support

For additional product information not contained in this manual, please contact General Monitors Customer Support. Refer to Section 4.0 for contact information.

# 1.0 Before Installation

## 1.1 System Integrity Verification

General Monitors' mission is to benefit society by providing solutions through industry leading safety products, services and systems that save lives and protect capital resources from the dangers of hazardous flames, gases and vapors.

The safety products you have purchased should be handled carefully and installed, calibrated and maintained in accordance with the respective product instruction manual. Remember these products are for your safety.

To ensure operation at optimum performance, General Monitors recommends that certain maintenance items be performed.

## 1.2 Commissioning Safety Systems

Before power up, verify wiring, terminal connections, and stability of mounting for all integral safety equipment including, but not limited to:

- Power supplies
- Control modules
- Field detection devices
- Signaling / output devices
- Accessories connected to field and signaling devices

After the initial application of power and any factory specified warm-up period to the safety system, verify that all signal outputs to and from devices and modules are within the manufacturer's specifications. Initial calibration, calibration checking or testing should also be performed according to the manufacturer's recommendations and instructions.

Proper system operation must be verified by performing a full functional test of all component devices of the safety system, ensuring that the proper levels of alarming occur.

Fault/Malfunction circuit operation should be verified.

## 1.3 Periodic Testing and Calibration of Field Devices

Periodic testing or calibrating should be performed per the manufacturer's recommendations and instructions. Testing and calibration procedures should include, but not be limited to the following:

- Verify zero reading on the control instrument, General Monitors' Model IR400, IR2100 or IR4000S/M
- Verify applied calibration gas pressure as recommended by the manufacturer
- Ensure no gas leak at the supply calibration gas line
- Make sure the calibration gas tank is not empty and the regulator is at the proper setting
- Apply a known concentration of gas, or a simulated test device provided by the manufacturer

When testing produces results outside of the manufacturer's specifications, re-calibration or repair/replacement of the suspect device(s) should be performed as necessary. Calibration

intervals should be independently established through a documented procedure, including a calibration log maintained by plant personnel or third party testing services.



## **1.4 Special Warning**

Through engineering design, testing, manufacturing techniques, and rigid quality control, General Monitors (GM) supplies the finest gas detection systems available. The user must recognize his responsibility for maintaining the gas detection system in operational condition.

General Monitors' gas detection systems are primarily safety devices for the protection of personnel and facilities and must be "always ready". With proper installation, calibration, and maintenance, the system provides continuous monitoring of hazardous areas. The user must assume all liability for misuse of General Monitors' gas detection systems.

The system's full two-year warranty will be voided if customer personnel, or third parties, damage the system during repair attempts.

## 2.0 Introduction

### 2.1 Description

The Remote Gas Calibrator for IR (RGC-IR) is designed for use with General Monitors Models IR2100 / IR400 Infrared Point Detectors for hydrocarbon gas applications (see Figure 1).

The unit allows for the calibration and detection of the IR2100/IR400 Detectors in various winds and temperatures. The unit is used for blocking the ambient air and re-directing the gas to the IR path for sensor calibration.

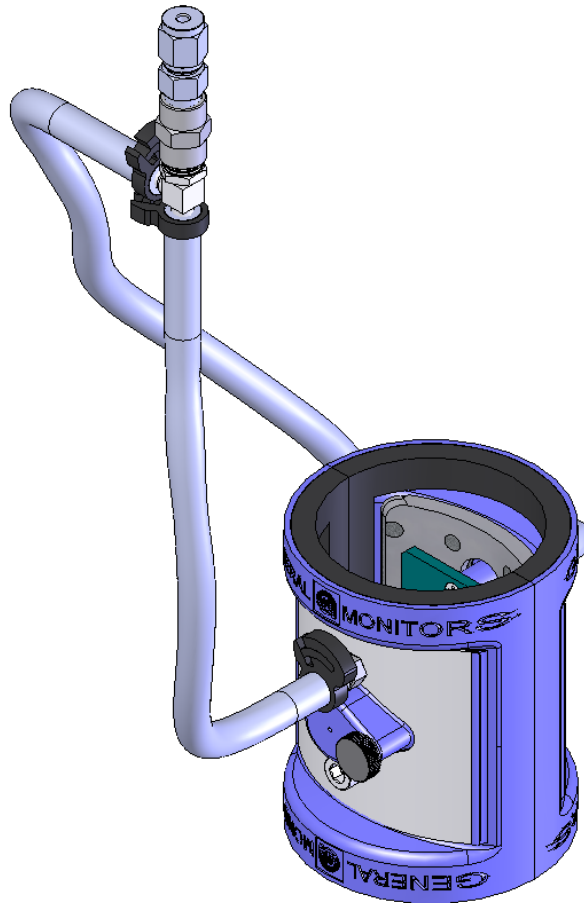

**Figure 1: RGC (P/N 32541-1)**

The RGC-IR allows for remote calibration of the IR2100 / IR400 to 50% LEL methane or other light hydrocarbon gases.

## 3.0 Installation

The basic steps in a typical installation are listed in the sections below. The installation process may vary depending on the exact site configuration. Only skilled and trained personnel must perform installation and maintenance.

The following items are required for a set-up for remote gas calibration:

- a. Calibration cylinder (ex. 50% LEL methane in air)
- b. Regulator, which can supply  $50 \pm 5$  psi to RGC-IR
- c. 1/8 inch stainless steel gas line
- d. Vent line (refer to Remote Manual Gasing in Section 3.1)

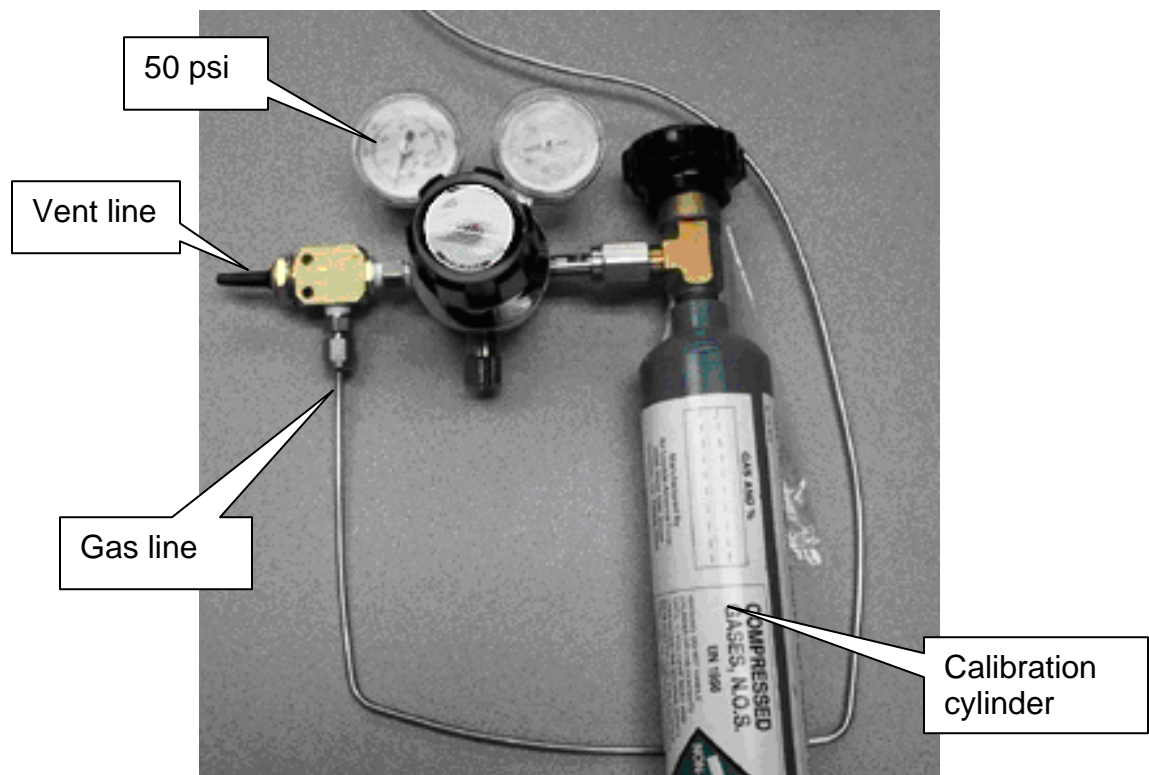

Figure 2: Gas Cylinder and Regulator

### 3.1 Installation Options

The RGC-IR can be configured for the following options:

#### a. Remote Manual Gassing (Configuration 1):

Remote Manual Gassing Installation	
1	Attach the RGC-IR to the sensor
2	Attach the gas inlets line to RGC-IR inlets
3	Set regulator's outlet pressure to $50 \pm 5$ psi
4	Open gas valve. Once gas valve has been opened, check for leaks.
5	Close gas valve.
6	Open the vent line. By opening the vent line the RGC-IR opens, allowing ambient air to come into calibration chamber.
7	Follow sensor calibration in Section 3.2

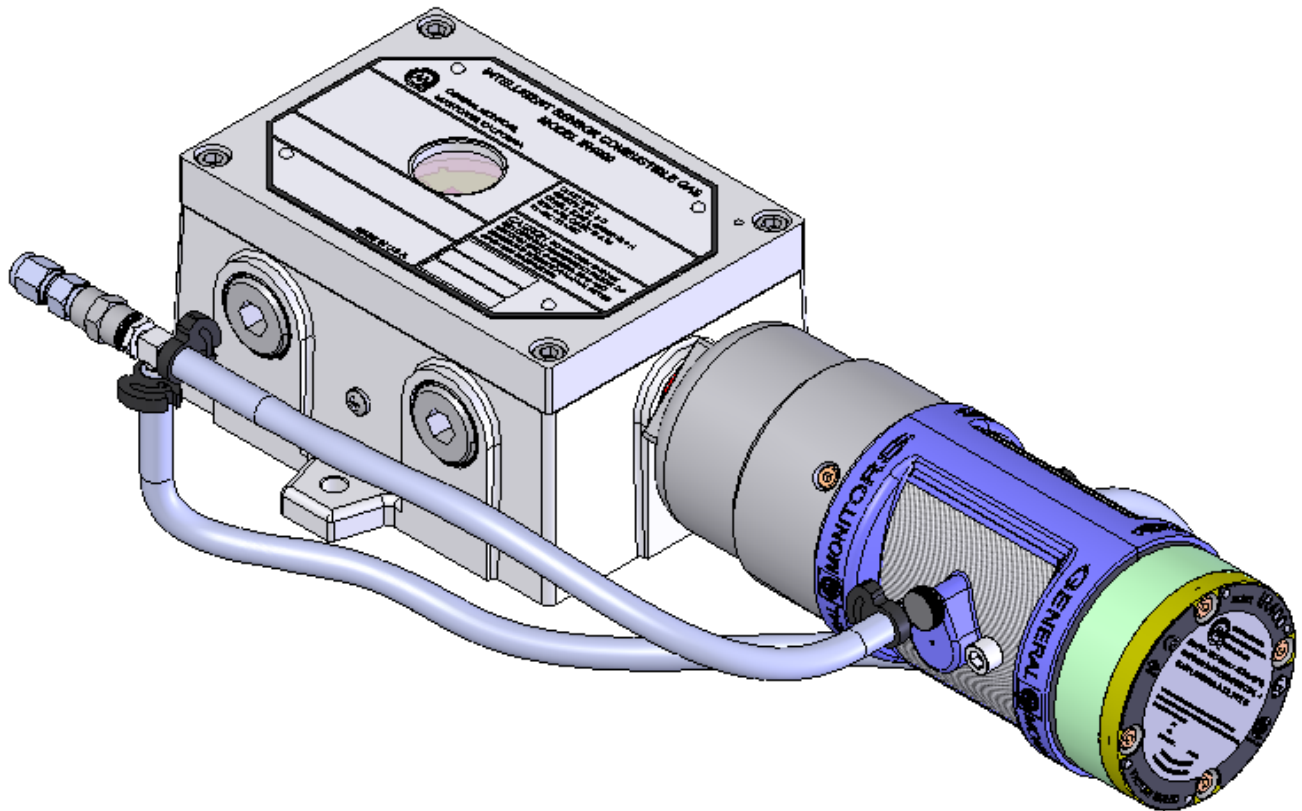

**Figure 3: IR4000S with IR400 and RGC-IR (P/N 32541-1) for Manual Gassing**

The RGC-IR can be 100 feet from the 50% LEL methane cylinder when using 1/8" diameter stainless steel tubing, and a delivery pressure between 45 psi to 55 psi at the RGC-IR.

Before using the remote RGC-IR, the tubing must be purged with gas to remove any air. This can be done by activating the gas check several times until a stable reading is obtained.

### 3.2 Sensor Calibration using RGC-IR

For Manual Gassing:

1. Startup the IR4000S / IR4000M in normal calibration mode according to the IR4000S or IR4000M instruction manual.
2. When the instrument displays a steady "**AC**", open the gas valve. The RGC-IR's shutters will close and the display will show a flashing "**CP**".
3. When instrument displays a steady "**CC**", close the gas valve, open the vent line, and the RGC-IR's shutters will open.
4. Remove the gas. You will continue to see the "**CC**" until the gas gets below 5% of full scale. The unit will then return to normal operation.
5. When instrument begins to show % LEL reading, the calibration is done.

---

**NOTE:** A pressure between 45 and 55 psi is required for closing the RGC-IR's shutter and maintaining the proper seal from ambient air.

---

## 4.0 Customer Support

### 4.1 General Monitors' Offices

Area	Phone / Fax / Email
<b>UNITED STATES</b>	
Corporate Office: 26776 Simpatica Circle Lake Forest, CA 92630	Phone: +1-949-581-4464, 800-446-4872 Fax: +1-949-581-1151 Email: info@generalmonitors.com
9776 Whithorn Drive Houston, TX 77095	Phone: +1-281-855-6000 Fax: +1-281-855-3290 Email: gmhou@generalmonitors.com
<b>UNITED KINGDOM</b>	
Heather Close Lyme Green Business Park Macclesfield, Cheshire, United Kingdom, SK11 0LR	Phone: +44-1625-619-583 Fax: +44-1625-619-098 Email: info@generalmonitors.co.uk
<b>IRELAND</b>	
Ballybrit Business Park Galway Republic of Ireland	Phone: +353-91-751175 Fax: +353-91-751317 Email: service@gmil.ie
<b>SINGAPORE</b>	
No. 2 Kallang Pudding Rd. #09-16 Mactech Building Singapore 349307	Phone: +65-6-748-3488 Fax: +65-6-748-1911 Email: genmon@gmpacifica.com.sg
<b>MIDDLE EAST</b>	
P.O. Box 61209 Jebel Ali, Dubai United Arab Emirates	Phone: +971-4-8143814 Fax: +971-8-4480051 Email: gmme@generalmonitors.ae

### 4.2 Other Sources of Help

General Monitors provides extensive documentation, white papers, and product literature for the company's complete line of safety products. Many of these documents are available online at the General Monitors website at <http://www.generalmonitors.com>.

## 5.0 Appendix

### 5.1 Warranty

General Monitors warrants the Remote Gas Calibrator-IR to be free from defects in workmanship or material under normal use and service, within two (2) years from the date of shipment. General Monitors will repair or replace, without charge, any such defective equipment found to be defective during the warranty period. General Monitors' personnel will make full determination of the nature of, and responsibility for defective equipment. Defective or damaged equipment must be shipped prepaid to General Monitors' plant, or representative from which shipment was made. In all cases, this warranty is limited to the cost of the equipment supplied by General Monitors. The customer will assume all liability for the misuse of this equipment by its employees, or other personnel.

All warranties are contingent upon proper use in the application for which the product was intended. They do not cover products which have been modified, or repaired, without General Monitors' approval, or which have been subjected to neglect, accident, improper installation or application, or on which the original identification marks have been removed, or altered.

Except for the express warranty stated above, General Monitors disclaims all warranties with regard to the products sold, including all implied warranties of merchantability and fitness. The express warranty stated herein are in lieu of all obligations or liabilities, on the part of General Monitors for damages including, but not limited to, consequential damages arising out of/or in connection with, the use or performance of the product.

---

**NOTE:** The Remote Gas Calibrator-IR is easy to install; however, this manual should be read and understood before attempting to operate the system.

---

## 6.0 Specifications

### 6.1 Functional Specifications

The RGC-IR allows for remote calibration of the Models IR2100 / IR400 to 50% LEL methane or other light hydrocarbon gas.

### 6.2 Environmental Specifications

Operation Temperature:	-40°F (-40°C) to 167°F (75°C)
Storage Temperature:	-40°F (-40°C) to 167°F (75°C)
Humidity:	5% to 95% (non-condensing).
Air Velocity:	0 to 30 mph. (With error within 5 mph.)
Accuracy:	5% to 20 % of full scale depending on angle of air flow
Response Time:	T <sub>50</sub> < 6 seconds, T <sub>90</sub> < 9 seconds

### 6.3 Mechanical Specifications

Operation Pressure	50 psi +/- 5 psi
Maximum Tubing Length:	200 ft for 1/8 inch stainless steel tubing or 100 ft for 1/4 inch tubing (ID).

### 6.4 RGC-IR Dimensions and Outline Drawing

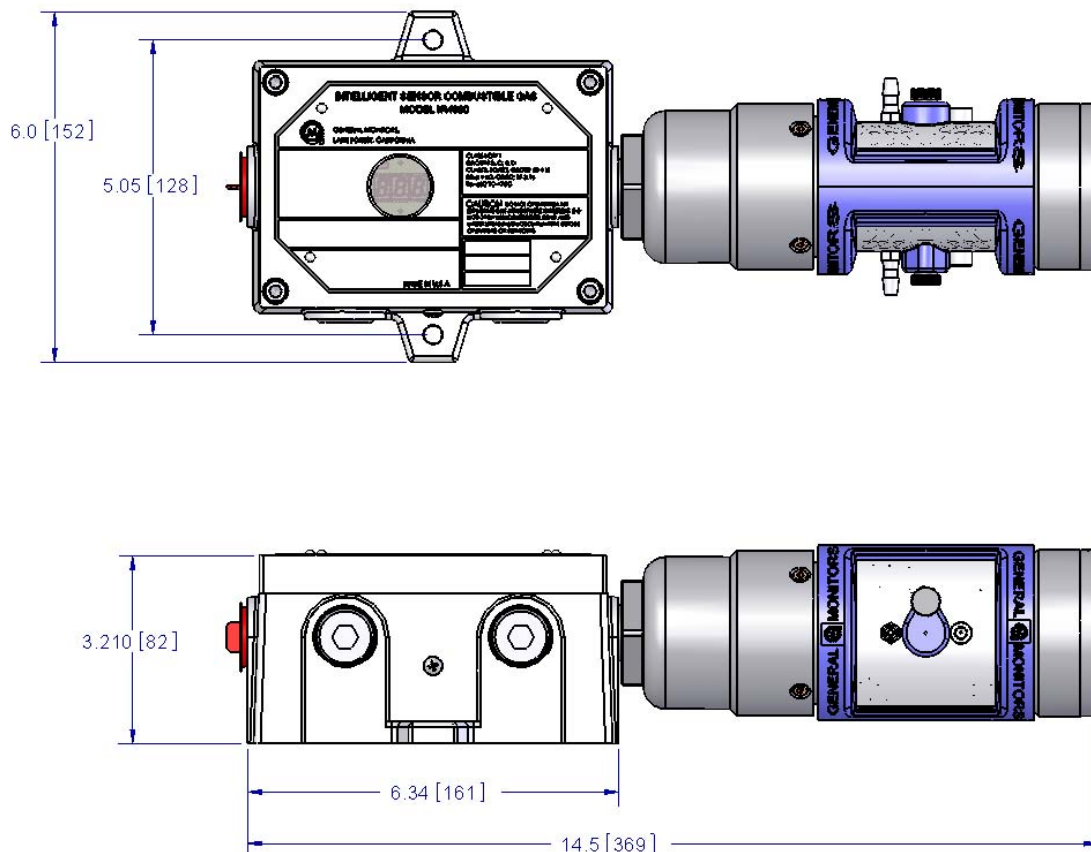

**Figure 4: RGC (32541-1) with IR4000S/M Dimensions and Outline Drawing**



**ADDENDUM**  
**Product Disposal Considerations**

This product may contain hazardous and/or toxic substances.

EU Member states shall dispose according to WEEE regulations. For further General Monitors' product WEEE disposal information please visit:

[www.generalmonitors.com/customer\\_support/faq\\_general.html](http://www.generalmonitors.com/customer_support/faq_general.html)

All other countries or states: please dispose of in accordance with existing federal, state and local environmental control regulations.