



**GENERAL MONITORS**

**ARGC**

# **Automatic Remote Gas Calibrator for S4000CH**



The information and technical data disclosed in this document may be used and disseminated only for the purposes and to the extent specifically authorized in writing by General Monitors.

**Instruction Manual**

**02-09**

General Monitors reserves the right to change published specifications and designs without prior notice.



**Part No.  
Revision**

**MANARGC-S4000CH  
B/02-09**

This page intentionally left blank

# Table of Contents

<b>TABLE OF FIGURES .....</b>	<b>IV</b>
<b>ABOUT THIS MANUAL .....</b>	<b>1</b>
Format Conventions.....	1
Notes, Cautions, and Warnings .....	1
Contacting Customer Support.....	1
<b>1.0 BEFORE INSTALLATION.....</b>	<b>2</b>
1.1 System Integrity Verification .....	2
1.2 Commissioning Safety Systems .....	2
1.3 Periodic Testing and Calibration of Field Devices .....	2
1.4 Special Warning .....	3
<b>2.0 INTRODUCTION .....</b>	<b>4</b>
2.1 Description .....	4
<b>3.0 INSTALLATION.....</b>	<b>5</b>
3.1 Installation Options.....	6
3.2 Sensor Calibration using RGC/ARGC .....	9
<b>4.0 CUSTOMER SUPPORT .....</b>	<b>10</b>
4.1 General Monitors' Offices .....	10
4.2 Other Sources of Help .....	10
<b>5.0 APPENDIX.....</b>	<b>11</b>
5.1 Warranty.....	11
<b>6.0 SPECIFICATIONS.....</b>	<b>12</b>
6.1 Functional Specifications .....	12
6.2 Environmental Specifications.....	12
6.3 Mechanical Specifications.....	12
6.4 RGC/ARGC Dimensions and Outline Drawing .....	12

## **Table of Figures**

Figure 1: RGC (P/N 80153-1) and Solenoid Valve Kit (P/N 80154-1).....	4
Figure 2: Gas Cylinder and Regulator .....	5
Figure 3: S4000CH with RGC (P/N 80153-1) for Manual Gassing .....	6
Figure 4: S4000CH with ARGC (P/N 80153-1 & 80154-1) for Automatic Local Gassing .....	7
Figure 5: ARGC w/Junction Box (P/N 80155-1) for Automatic Remote Gassing.....	8
Figure 6: RGC (80153-1) with S4000CH Dimensions and Outline Drawing.....	12
Figure 7: ARGC (80154-1 & 80153-1) with S4000CH Dimensions and Outline Drawing.....	13
Figure 8: ARGC with Remote Junction Box (80155-1) With S4000CH Dimensions and Outline Drawing.	14

## About This Manual

This manual provides instructions for installing, operating, and maintaining the General Monitors, Inc. (GMI) Automatic Remote Gas Calibrator (ARGC). The intended audience includes installation personnel, field service technicians, and other technical staff involved in installing and using the ARGC.

### Format Conventions

Several format conventions are used throughout this manual for Notes, Cautions, Warnings, User Menus, and Modbus notations. These conventions are described below.

### Notes, Cautions, and Warnings

---

**NOTE:** Notes provide supplementary details such as exception conditions, alternate methods for a task, time saving tips, and references to related information.

---



**CAUTION:** These notices describe precautions to prevent hazardous conditions that may damage the equipment.



**WARNING:** These notices describe precautions to prevent hazardous conditions that may cause injury to people working with the equipment.

### Contacting Customer Support

For additional product information not contained in this manual, please contact General Monitors Customer Support. Refer to Section 4.0 for contact information.

# 1.0 Before Installation

## 1.1 System Integrity Verification

General Monitors' mission is to benefit society by providing solutions through industry leading safety products, services and systems that save lives and protect capital resources from the dangers of hazardous flames, gases and vapors.

The safety products you have purchased should be handled carefully and installed, calibrated and maintained in accordance with the respective product instruction manual. Remember these products are for your safety.

To ensure operation at optimum performance, General Monitors recommends that certain maintenance items be performed.

## 1.2 Commissioning Safety Systems

Before power up, verify wiring, terminal connections, and stability of mounting for all integral safety equipment including, but not limited to:

- Power supplies
- Control modules
- Field detection devices
- Signaling / output devices
- Accessories connected to field and signaling devices

After the initial application of power and any factory specified warm-up period to the safety system, verify that all signal outputs to and from devices and modules are within the manufacturer's specifications. Initial calibration, calibration checking or testing should also be performed according to the manufacturer's recommendations and instructions.

Proper system operation must be verified by performing a full functional test of all component devices of the safety system, ensuring that the proper levels of alarming occur.

Fault/Malfunction circuit operation should be verified.

## 1.3 Periodic Testing and Calibration of Field Devices

Periodic testing or calibrating should be performed per the manufacturer's recommendations and instructions. Testing and calibration procedures should include, but not be limited to the following:

- Verify zero reading on the control instrument, General Monitors' Model S4000CH
- Verify applied calibration gas pressure as recommended by the manufacturer
- Ensure no gas leak at the supply calibration gas line
- Make sure the calibration gas tank is not empty and the regulator is at the proper setting
- Apply a known concentration of gas, or a simulated test device provided by the manufacturer

When testing produces results outside of the manufacturer's specifications, re-calibration or repair/replacement of the suspect device(s) should be performed as necessary. Calibration

intervals should be independently established through a documented procedure, including a calibration log maintained by plant personnel or third party testing services.



## **1.4 Special Warning**

Through engineering design, testing, manufacturing techniques, and rigid quality control, General Monitors (GM) supplies the finest gas detection systems available. The user must recognize his responsibility for maintaining the gas detection system in operational condition.

General Monitors' gas detection systems are primarily safety devices for the protection of personnel and facilities and must be "always ready". With proper installation, calibration, and maintenance, the system provides continuous monitoring of hazardous areas. The user must assume all liability for misuse of General Monitors' gas detection systems.

The system's full two-year warranty will be voided if customer personnel, or third parties, damage the system during repair attempts.

## 2.0 Introduction

### 2.1 Description

The Automatic Remote Gas Calibrator (ARGC) is designed for use with the General Monitors' Model S4000CH intelligent sensor. It is comprised of an RGC and solenoid valve (see Figure 1).

The unit is capable of allowing for the calibration and detection of the catalytic bead sensor to hydrocarbon gases in various winds and temperatures. The unit is used for blocking the ambient air and re-directing the gas to the catalytic bead sensor for sensor calibration.



**Figure 1: RGC (P/N 80153-1) and Solenoid Valve Kit (P/N 80154-1)**

The ARGC allows for remote calibration of the GM catalytic bead sensor to 50% LEL methane or other light hydrocarbon gases.

## 3.0 Installation

The basic steps in a typical installation are listed in the sections below. The installation process may vary depending on the exact site configuration. Only skilled and trained personnel must perform installation and maintenance.

In poorly ventilated areas, the gas concentration at the sensor may be lower than that outside the ARGC since the meshed cylinder of the ARGC reduces airflow to the sensor. Therefore, when installing a sensor with an ARGC in a space with little air flow, it is important to adjust the warning and alarm settings to a lower level.

The following items are required for a set-up for automatic gas calibration:

- a. Calibration cylinder (ex. 50% LEL methane in air)
- b. Regulator, which can supply  $45 \pm 5$  psi to ARGC
- c. 1/8 inch stainless steel gas line
- d. Vent line for Configuration 1 only (refer to Remote Manual Gasing in Section 3.1)

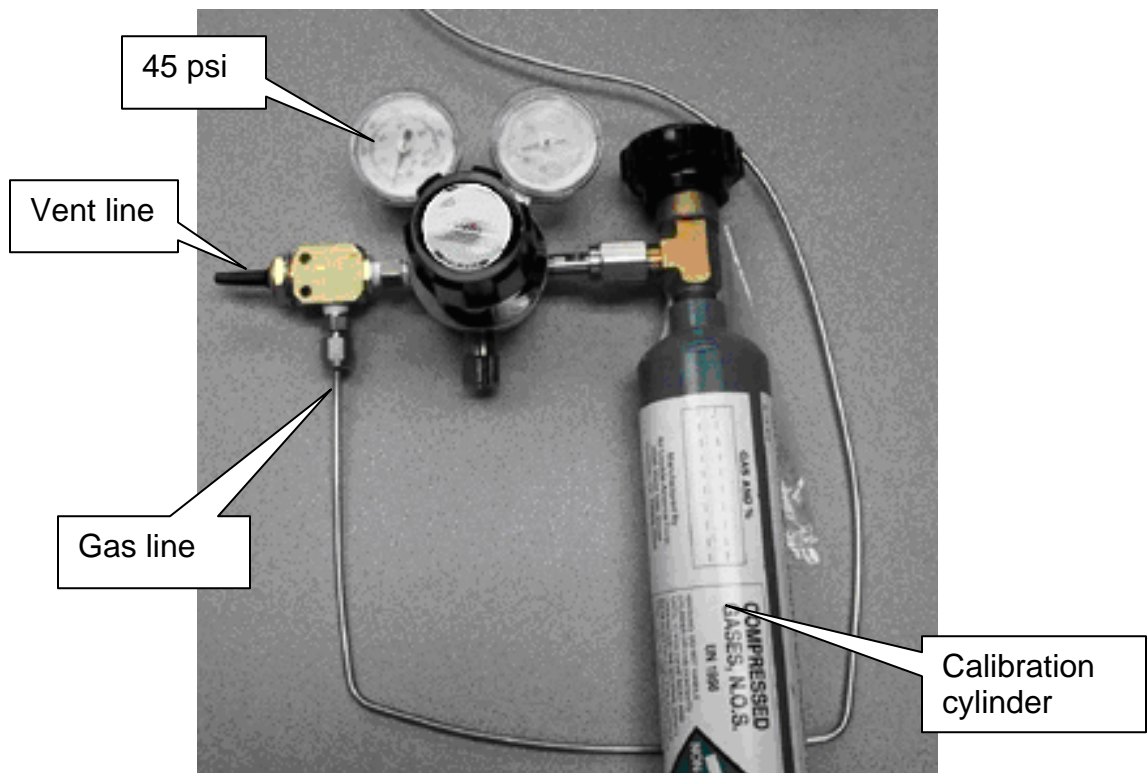

Figure 2: Gas Cylinder and Regulator

### 3.1 Installation Options

The RGC/ARGC can be configured for the following three options:

#### a. Remote Manual Gassing (Configuration 1):

Remote Manual Gassing Installation	
1	Attach RGC to the sensor
2	Attach the gas inlet line to RGC inlet
3	Set regulator's outlet pressure to $45 \pm 5$ psi
4	Open gas valve. Once gas valve has been opened, check for leaks and ensure that the RGC's plunger is closed.
5	Close gas valve.
6	Open the vent line. By opening the vent line the RGC's plunger opens, allowing ambient air to come into contact with the sensor.
7	Follow sensor calibration in Section 3.2

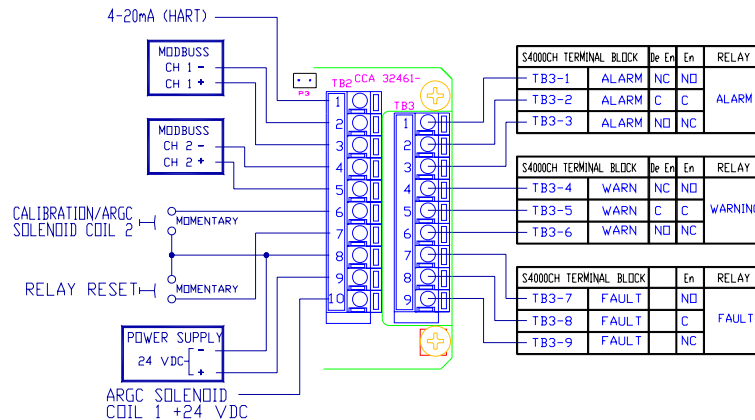

Figure 3: S4000CH with RGC (P/N 80153-1) for Manual Gassing

**b. Automatic Local Gasing (Configuration 2):**

<b>Automatic Local Gasing Installation</b>	
1	Attach RGC to the sensor Attach ARGC solenoid valve to sensor/remote box
2	Attach the gas inlet line to ARGC solenoid inlet
3	Set regulator's outlet pressure to 45 ± 5 psi at ARGC
4	Open gas valve. Once gas valve has been opened, check for leaks and ensure that the RGC's plunger is still open.
5	Activate the ARGC solenoid valve with a Hart or Modbus command. On activation, gas flows into the chamber and the plunger closes.
6	De-activate the ARGC solenoid valve. The ARGC should now be open allowing the sensor to be exposed to air. Wait until sensor stabilizes.
7	Follow sensor calibration in Section 3.2



**Figure 4: S4000CH with ARGC (P/N 80153-1 & 80154-1) for Automatic Local Gassing**

---

**NOTE:** The ARGC requires extra power. The ARGC only works properly when installed using GMI supplied parts.

---

**c. Automatic Remote Gassing (Configuration 3):**

Automatic Remote Gassing Installation	
1	Remove sensor from sensor box, then attach sensor to remote junction box and attach RGC to the sensor Attach ARGC solenoid valve to remote junction box
2	Attach the gas inlet line to ARGC solenoid inlet
3	Set regulator's outlet pressure to 45 ± 5 psi
4	Open gas valve. Once gas valve has been opened, check for leaks and ensure that the RGC's plunger is still open.
5	Activate the ARGC solenoid valve with a HART or Modbus command, On activation, gas flows into the chamber and the plunger closes.
6	De-activate the ARGC solenoid valve. The ARGC should now be open allowing the sensor to be exposed to air. Wait until sensor stabilizes.
7	Follow sensor calibration in Section 3.2

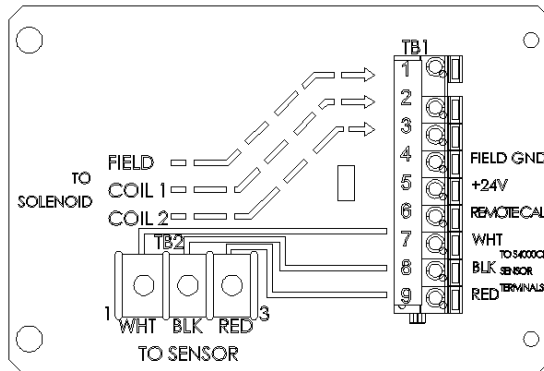

**Figure 5: ARGC w/Junction Box (P/N 80155-1) for Automatic Remote Gassing**

The ARGC can be 1000 feet from the 50% LEL methane cylinder when using 1/8" diameter stainless steel tubing, and a delivery pressure between 40 PSI to 50 PSI at the ARGC.

Before using the remote ARGC the tubing must be purged with gas to remove any air. This can be done by activating gas check several times until a stable reading is obtained.

### 3.2 Sensor Calibration using RGC/ARGC

For Configuration 1:

1. Startup S4000CH in normal calibration mode according to the S4000CH instruction manual. Do not enable the ARGC mode for this configuration.
2. When instrument displays "**AC**" open gas valve. The RGC's plunger should close and the display will show "**CP**".
3. When instrument displays "**CC**" close gas valve, vent line, and the RGC's plunger should open.
4. When instrument begins to show % LEL reading, the calibration is done.

For Configurations 2 and 3:

- a. Startup S4000CH in ARGC calibration mode according to the S4000CH instruction manual. ARGC mode is enabled.
- b. Activate Calibration command using a HART or Modbus command. The ARGC solenoid valve opens, letting gas flow into the sensor for Calibration/Gas Check. The instrument displays "**CP**".
- c. When instrument displays "**CC**" the solenoid closes and the RGC's plunger opens.
- d. When instrument begins to show % LEL reading, the calibration is done.

**NOTE:** A pressure between 40 and 50 psi is required for both closing the RGC's plunger and maintaining the proper gas flow to calibrate the sensor.

**NOTE:** General Monitors recommends verifying the first calibration (or first calibration after sensor replacement) visually. When the solenoid opens and gas is applied, the plunger will close and the plunger shaft should be visible through the mesh screen. When calibration is complete, the gas will vent and the plunger will open. After this initial calibration, the S4000CH firmware will be able to verify correct operation of the RGC and calibration can be done remotely.

Calibration Sequence	S4000CH Display	Modbus or HART Mode Reported
Zeroing	Flashing sensor life number, then AC	Zeroing
Gas Check	CP	Gas Check
Spanning	CP	Spanning
Calibration Complete	CC	Calibration Complete

**ARGC Calibration Sequence**

## 4.0 Customer Support

### 4.1 General Monitors' Offices

Area	Phone / Fax / Email
<b>UNITED STATES</b>	
Corporate Office: 26776 Simpatica Circle Lake Forest, CA 92630	Phone: +1-949-581-4464, 800-446-4872 Fax: +1-949-581-1151 Email: sales@generalmonitors.com
9776 Whithorn Drive Houston, TX 77095	Phone: +1-281-855-6000 Fax: +1-281-855-3290 Email: gmhou@generalmonitors.com
<b>UNITED KINGDOM</b>	
Heather Close Lyme Green Business Park Macclesfield, Cheshire, United Kingdom, SK11 0LR	Phone: +44-1625-619-583 Fax: +44-1625-619-098 Email: info@generalmonitors.co.uk
<b>IRELAND</b>	
Ballybrit Business Park Galway Republic of Ireland	Phone: +353-91-751175 Fax: +353-91-751317 Email: service@gmil.ie
<b>SINGAPORE</b>	
No. 2 Kallang Pudding Rd. #09-16 Mactech Building Singapore 349307	Phone: +65-6-748-3488 Fax: +65-6-748-1911 Email: genmon@gmpacifica.com.sg
<b>MIDDLE EAST</b>	
LOB12, #G20 P.O. Box 61209 Jebel Ali, Dubai United Arab Emirates	Phone: +971-4-8815751 Fax: +971-4-8817927 Email: gmme@emirates.net.ae

### 4.2 Other Sources of Help

General Monitors provides extensive documentation, white papers, and product literature for the company's complete line of safety products. Many of these documents are available online at the General Monitors website at <http://www.generalmonitors.com>.

## 5.0 Appendix

### 5.1 Warranty

General Monitors warrants the Remote Gas Calibrator/Automatic Remote Gas Calibrator to be free from defects in workmanship or material under normal use and service, within two (2) years from the date of shipment. General Monitors will repair or replace, without charge, any such defective equipment found to be defective during the warranty period. General Monitors' personnel will make full determination of the nature of, and responsibility for defective equipment. Defective or damaged equipment must be shipped prepaid to General Monitors' plant, or representative from which shipment was made. In all cases, this warranty is limited to the cost of the equipment supplied by General Monitors. The customer will assume all liability for the misuse of this equipment by its employees, or other personnel.

All warranties are contingent upon proper use in the application for which the product was intended. They do not cover products which have been modified, or repaired, without General Monitors' approval, or which have been subjected to neglect, accident, improper installation or application, or on which the original identification marks have been removed, or altered.

Except for the express warranty stated above, General Monitors disclaims all warranties with regard to the products sold, including all implied warranties of merchantability and fitness. The express warranty stated herein are in lieu of all obligations or liabilities, on the part of General Monitors for damages including, but not limited to, consequential damages arising out of/or in connection with, the use or performance of the product.

---

**NOTE:** The Remote Gas Calibrator/Automatic Remote Gas Calibration is easy to install; however, this manual should be read and understood before attempting to operate the system.

---

## 6.0 Specifications

### 6.1 Functional Specifications

The ARGC allows for remote calibration of the GMI catalytic bead sensor to 50% LEL methane or other light hydrocarbon gas.

### 6.2 Environmental Specifications

Operation Temperature:	-40° F (-40°C) to 167° F (75°C)
Storage Temperature:	-40° F (-40°C) to 167° F (75°C)
Humidity:	5% to 95% (non-condensing).
Air Velocity:	0 to 50 mph. (With error within 5 mph.)
Accuracy:	5% to 20 % of full scale depending on angle of air flow
Response Time:	T <sub>50</sub> < 10 seconds, T <sub>90</sub> < 30 seconds
Electrical:	24 VDC

### 6.3 Mechanical Specifications

Operation Pressure	45psi +/- 5 psi
Maximum Tubing Length:	200 ft for 1/8 inch stainless steel tubing or 100 ft for 1/4 inch tubing (ID). When using the Remote ARGC the tubing length is much longer

### 6.4 RGC/ARGC Dimensions and Outline Drawing

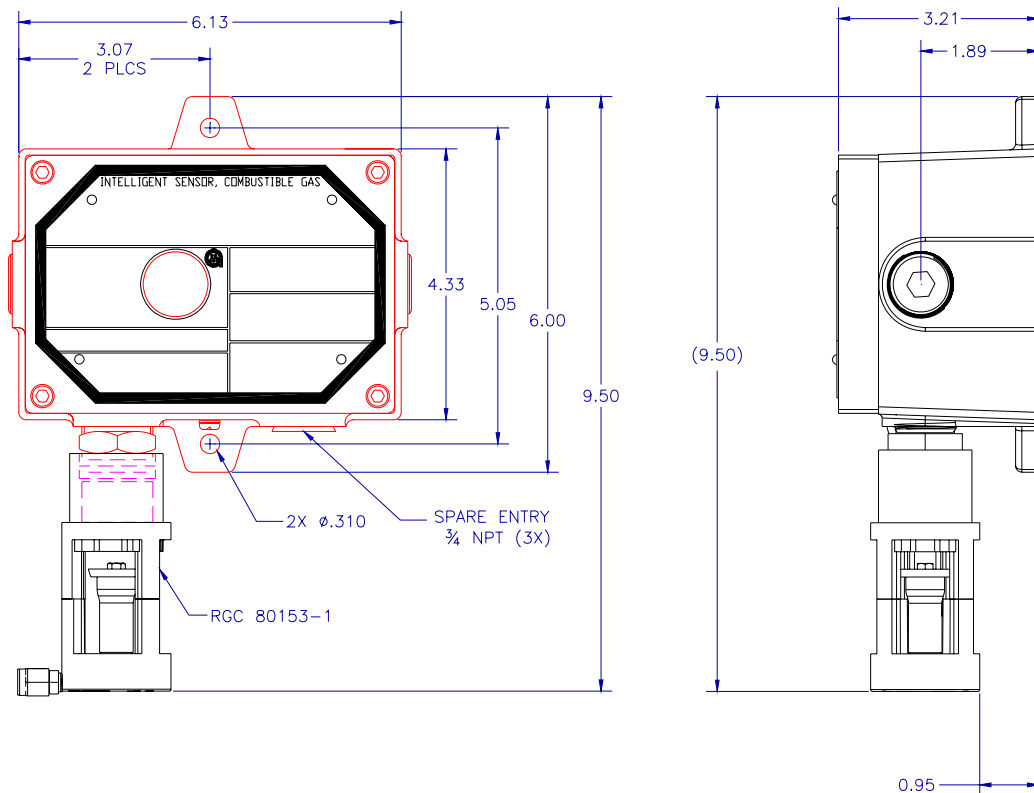

**Figure 6: RGC (80153-1) with S4000CH Dimensions and Outline Drawing**

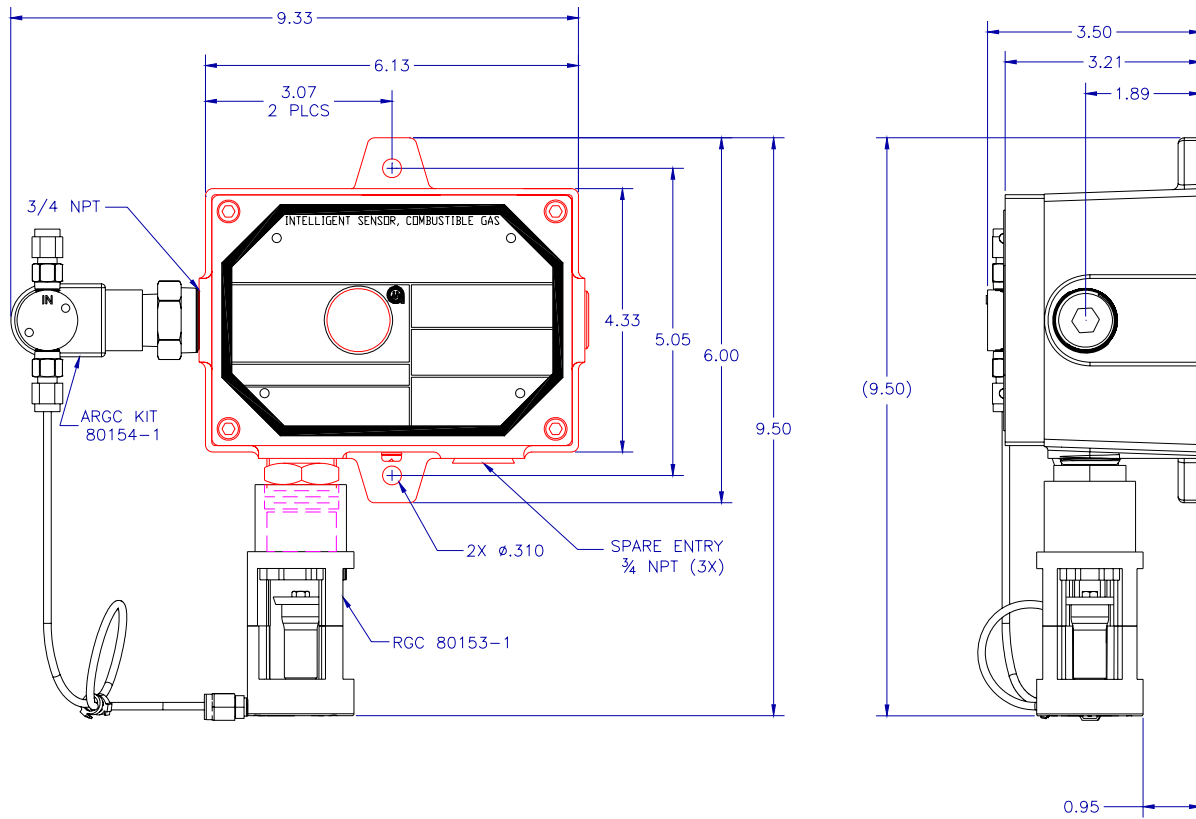

**Figure 7: ARGC (80154-1 & 80153-1) with S400CH Dimensions and Outline Drawing**

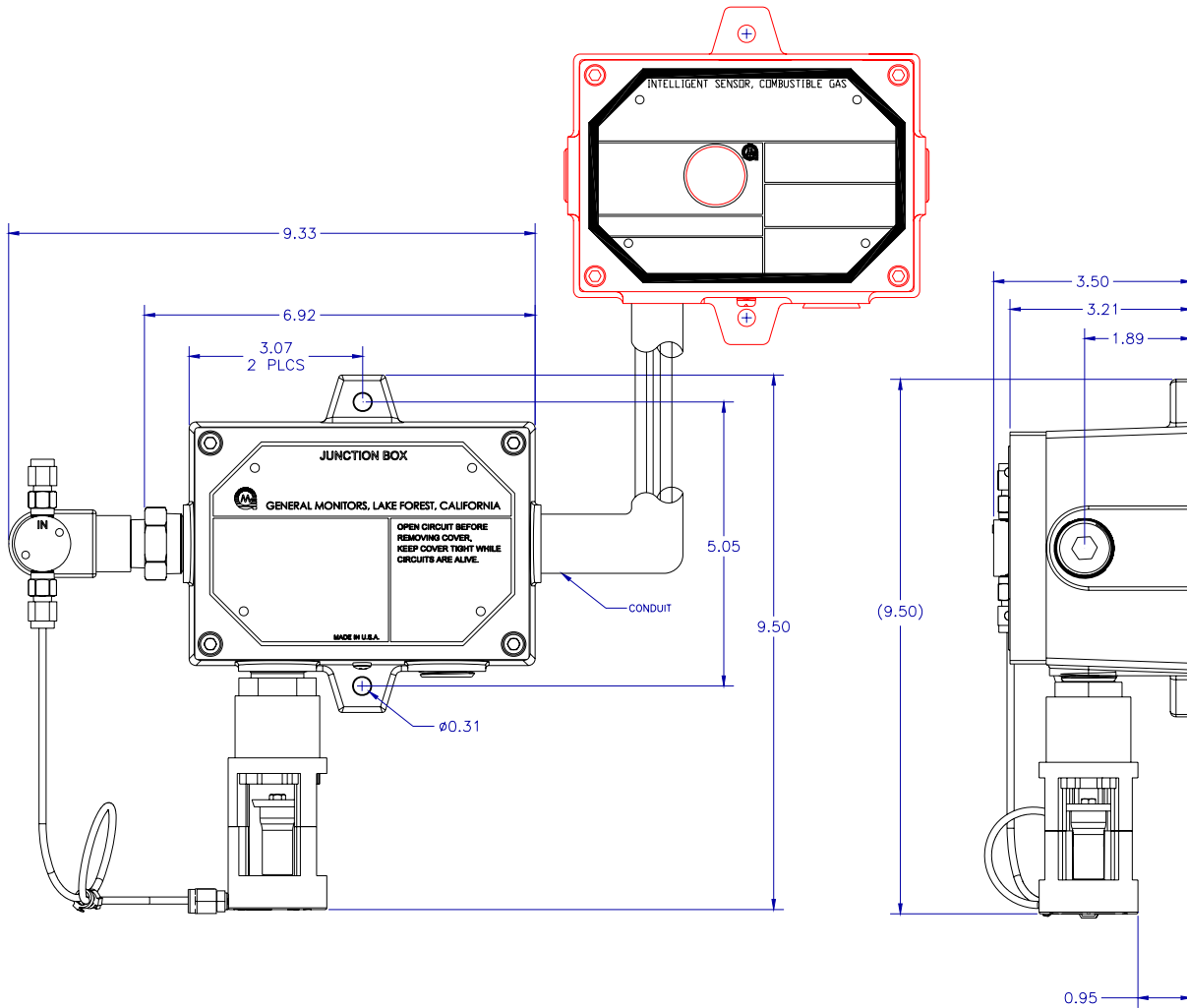

**Figure 8: ARGC with Remote Junction Box (80155-1) With S400CH Dimensions and Outline Drawing**



**ADDENDUM**  
**Product Disposal Considerations**

This product may contain hazardous and/or toxic substances.

EU Member states shall dispose according to WEEE regulations. For further General Monitors' product

WEEE disposal information please visit:

[www.generalmonitors.com/customer\\_support/faq\\_general.html](http://www.generalmonitors.com/customer_support/faq_general.html)

All other countries or states: please dispose of in accordance with existing federal, state and local environmental control regulations.