

INFRARED TECHNOLOGY FOR FAIL-TO-SAFE HYDROCARBON GAS DETECTION

Authors: Dr. Shankar Baliga is Senior Development Scientist for General Monitors. He has a Ph.D. in Physics from the Ohio State University with over twelve years of experience in the optical and sensor industry. Mr. Shafiq Khan is Director of Research & Development for General Monitors. He has a M.S. in Electrical Engineering from Michigan Tech. University with twenty years of experience in gas and fire detection technology development.

ABSTRACT

Continuing advances in infrared technology have resulted in fail-to-safe hydrocarbon gas point detectors that continuously monitor combustible gases and vapors within the lower explosive limit (LEL) and provide alarm indication. Other features of these detectors include operation in oxygen deficient or enriched areas, lack of routine calibration, immunity to poisons and RS-485 communications link along with 4-20 mA output. Another application of infrared technology is open path detection, which complements point detection. With an open path system there is no definite fixed path length for measuring gas leaks so the measurement is expressed in terms of concentration times path length. The open path system incorporates many of the same advantages of the optical point detector and includes a dual range, ppm.m for small hydrocarbon leaks and LEL.m for more catastrophic leaks.

INTRODUCTION



Catalytic-type combustible sensors have commonly been used to detect potentially flammable levels of hydrocarbon gas leaks and buildups but suffer from several drawbacks such as sensor poisoning and contamination by harsh environments, and the need for oxygen to maintain sensor accuracy. In the past few years, continuing advances in infrared technology have provided a more reliable yet reasonably priced alternative in infrared absorption based combustible gas sensors. The increased reliability also results in cost savings via reduced maintenance in refineries, petrochemical and gas producing plants. As described in this article, infrared absorption is an active technology to be distinguished from passive technologies of which the electrocatalytic bead is the most common.

LIMITATIONS OF ELECTROCATALYTIC TECHNOLOGY

The heart of an electrocatalytic or catalytic bead sensor is a platinum coil that is coated with a catalyst. This element is heated, and in the presence of a combustible gas a reaction takes place on the surface of this element with oxygen in the air to heat up the catalytic element. This causes a change within the embedded coil that is measured and monitored. The sensor also uses a reference bead that is passivated

with glass coating; the reference compensates for changes in temperature, humidity and pressure without responding to combustible gases that do not penetrate the coating. The catalyst employed in these sensors is critical to the accuracy and life of the sensor, and impacts the variety of combustible gases the sensor can detect.

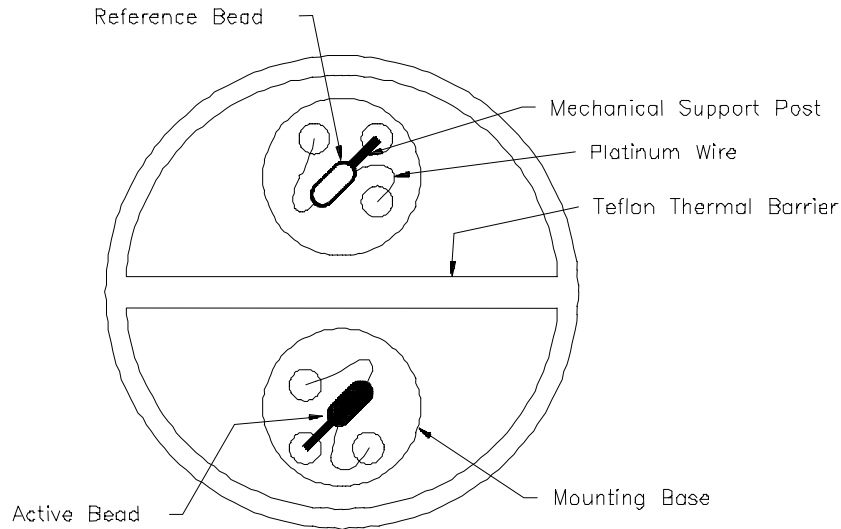

Fig. 1 Catalytic Bead Sensor

Though catalytic bead sensors have been in use for decades the technology does have some drawbacks. A main drawback is the inability to operate in an environment deficient in oxygen since the bead requires efficient oxidation of hydrocarbon gas; oxygen levels impact oxidation efficiency and hence, the sensor's accuracy. Another drawback is the possibility of sensor poisoning by chemical compounds such as silicones and sulfur compounds leading to a decline in catalytic activity. Contamination of the sensor is also possible, for example, by trapping of dust in the flame arrestor or exposure to heavy oils and greases. Contamination can show up during normal maintenance of the system as an increase in the response time to calibration, recovery time after exposure and loss of exposure.

Since these conditions can occur without warning to the operator, electrocatalytic hydrocarbon sensors are not fail-to-safe; fail-to-safe in this instance implies the sensor's ability to communicate its dysfunctional status to the operator for the various failure modes. For example, the operator may not know the poisoned status of the catalytic bead until calibration gas is required. This results in an increase in calibration intervals in areas where poisoning agents are suspected to exist.

Although the infrared technology described in this paper is gradually becoming the preferred method of gas detection, catalytic sensors are still the sensor of choice when it comes to operating the sensor head above 75°C. This is because of its ability to withstand and operate at much higher temperatures (up to 200°C) than the commonly used devices in infrared technology. Also, when calibrating a unit in the field or for calibrating a unit to a different gas in the field, the procedure may be simpler with the catalytic bead owing to sensor linearity.

Hydrocarbon sensors based on infrared absorption (IR) principles do not suffer from the drawbacks of catalytic bead sensors described above. This leads to increased reliability and a hydrocarbon monitoring system that can operate maintenance free for years. IR absorption based instruments offer fail-to-safe operation since the optical technology is an active one, able to communicate the sensor's status and faults to the operator. The IR hydrocarbon gas detector can be classified into two types known as point detectors and open path detectors.

IR GAS SENSING TECHNOLOGY

The infrared (IR) method of measuring gas concentration is based on the absorption of IR radiation at certain wavelengths as the radiation passes through a volume of the gas. IR hydrocarbon gas detectors can be classified into two types known as point detectors and open path detectors. For point detectors, the absorption path length is fixed, and is determined by the instrument design to be a few inches. For the open path IR detectors, the absorption path length can be as long as 100 meters as opposed to the few inches of the point detector.

Instruments based on IR technology use two wavelengths, one at the gas absorbing wavelength and the other at a wavelength not absorbed by the gas; neither wavelength is absorbed by the other atmospheric constituents such as water vapor, nitrogen, oxygen or carbon dioxide.

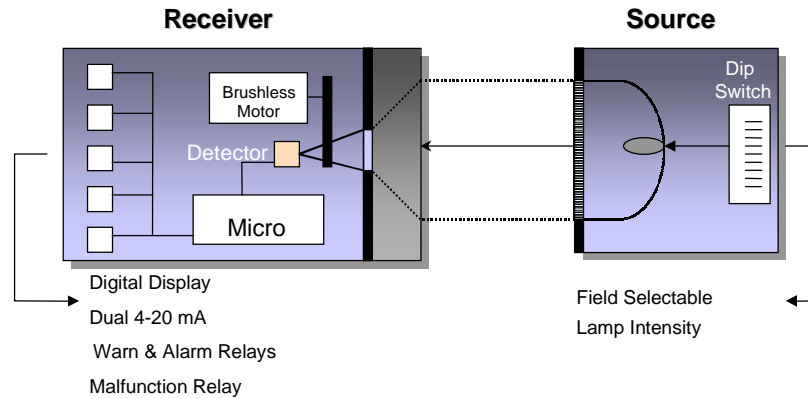

Fig. 2 Open Path Infrared System

IR gas sensing technology provides for fail-to-safe operation in contrast to electrocatalytic sensors since optical sensing is an active technology, which continuously monitors for sensor faults and communicates them to the user. This is achieved chiefly through the use of the second or reference wavelength. IR detectors are also immune to poisoning, resistant to corrosion, can operate in a deficit or surplus of oxygen, and have no reduction in sensor life from repeated exposure to gas. With the sophisticated optical and electronic designs currently being used, the detectors are factory calibrated and virtually maintenance free. This is particularly desirable when sensors must be located in inaccessible areas and cannot be easily calibrated on a periodic basis.

Point IR Detectors

Point combustible gas detectors are used to monitor the presence of flammable levels of hydrocarbon gas or vapor in industrial environments such as refineries and chemical plants. If the concentration of the hydrocarbon gas or vapor exceeds its Lower Explosive Level (LEL) the gas can be ignited leading to an explosion. Point combustible gas detectors are therefore located at several dozen sites to monitor for gas leaks. In the point IR detector, the concentration of hydrocarbon gas is measured via the infrared absorption of an optical beam known as the active beam.

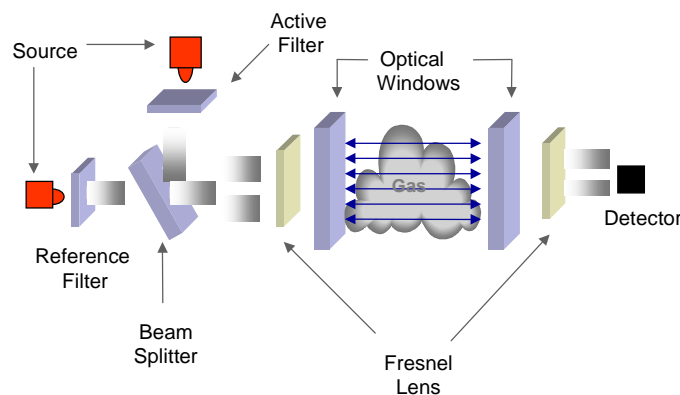

Fig. 3 Model IR2100 Point Detector – optical scheme

A second optical beam known as the reference follows the same optical path as the active but contains radiation at a wavelength not absorbed by the gas. This second beam provides for the fail-to-safe operation of the point IR detector which feature is not available with the electrocatalytic technology.

In the Model IR2100 manufactured by General Monitors, the two wavelengths are generated by two infrared sources which have the active and reference filters attached to them, are pulsed alternately and guided by the optics onto a common optical path. A detector receives the two optical pulses after they have traversed the optical absorption path. All the components of the instrument are mounted inside an explosion-proof housing with infrared transparent optical windows. Maintenance on IR detectors is typically limited to periodic cleaning of the optical windows and reflectors to ensure dependable performance. The current availability of reliable, low cost electronics and solid state IR detectors have reduced costs and made the technology feasible for many commercial applications.

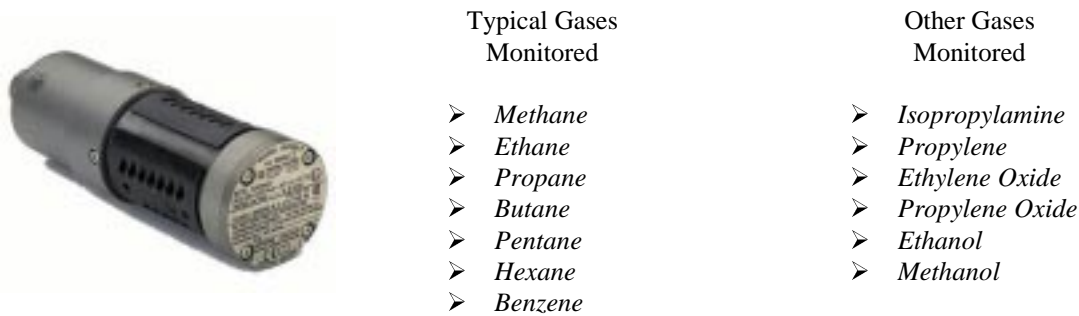

Fig. 4 Model IR2100 - Infrared Point Gas Detector

The signals from the IR detector are converted into digital format and processed by a microprocessor with the help of a gas concentration lookup table and correction factor for ambient temperature. The instrument outputs a 4-20 mA analog signal as well as a RS485 serial output. Use of the RS485 using MODBUS RTU Protocol provides two-way addressable communications for status, alarm, fault and other information for operation, trouble shooting or programming the unit. MODBUS also permits linking of up to 128 point detectors in series and up to 247 point detectors using repeaters. A typical system configuration linking 20 gas detectors and 20 flame detectors is shown in Fig. 5.

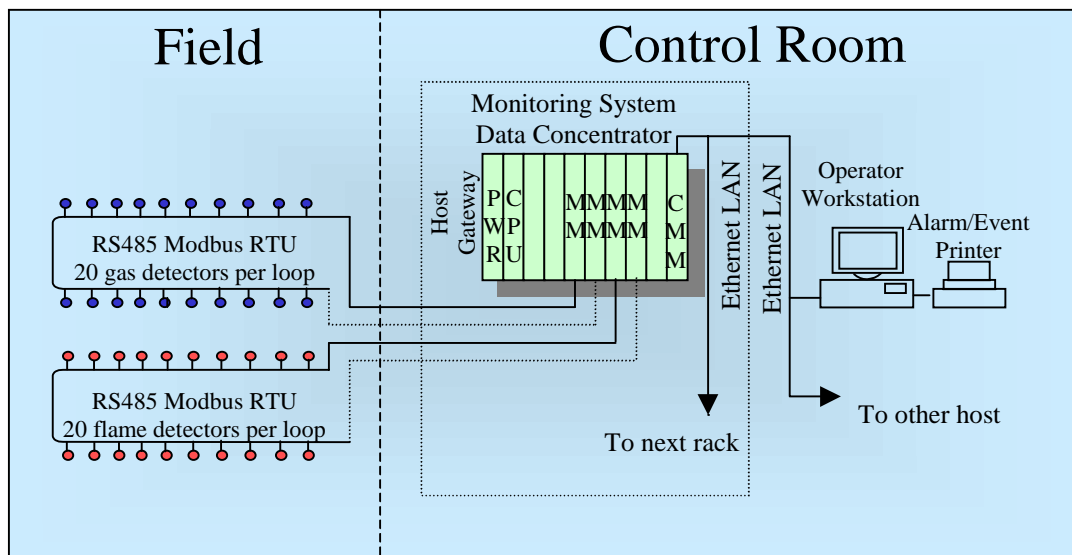

Fig. 5 Multi-drop Addressable System

The gas tables of up to eight gases can be stored in the memory of the microprocessor; the gases include the hydrocarbons of the series methane, ethane and propane as well as ethylene and benzene. These and other gases (see Fig. 4 for a list which is not exhaustive) can be detected in the 0 to 100% LEL range, though the unit is also capable of measuring 0 to 100% V/V if desired. The limiting factor of this IR technology is that the gas to be measured has to be infrared active such as the hydrocarbons. A point IR detector that has been modified to be sensitive to the appropriate absorbing wavelength can also monitor gases other than hydrocarbons. An example of this is the IR7000 point IR detector that is capable of measuring 0 to 2000 ppm of carbon dioxide. Such an instrument is obtained from the standard IR2100 by using optics and filters suited to the 4.3 micron absorption band of carbon dioxide.

The IR2100 and IR7000 infrared point gas detectors are available with demonstration and setup software (Fig. 6) which permit the actual signal levels and gas readings to be observed on a monitor screen in real time, along with the temperature and 4 to 20 mA output. Fault and alarm conditions may also be observed.

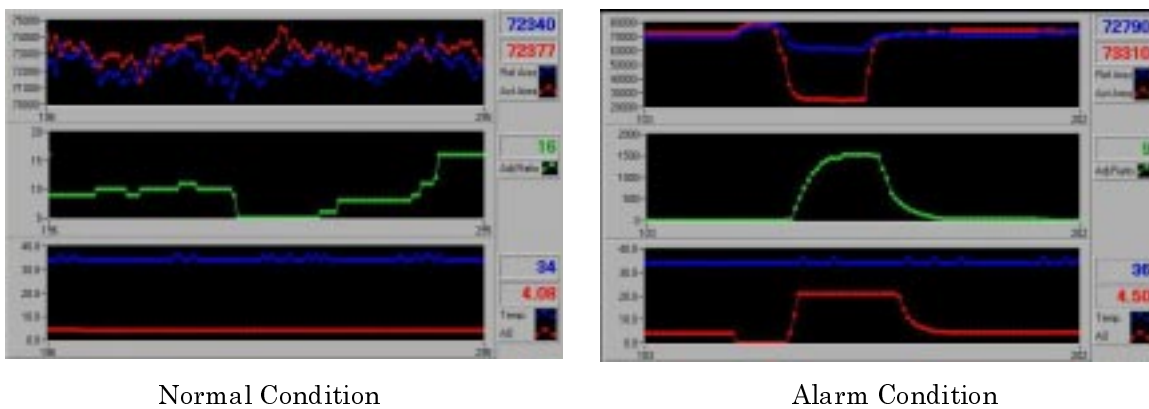

Fig. 6 Point IR Software Diagnostic Screens

Open Path IR Detectors

In open path IR gas detectors, the concepts of the point IR detector are expanded to a gas sampling path which can be as long as 100 meters as opposed to a few inches internal to the instrument. These systems can either use a retro-reflector or, as is the case with the Model IR5000 from General Monitors, use separate IR transmitters and receivers housed in explosion-proof housings. In the IR5000, the active and reference wavelengths for hydrocarbon detection are alternately selected via a rotating filter wheel, while the source is a broadband IR emitter. Open path IR detectors offer many of the same advantages as the point IR technology such as immunity to poisons, high sensitivity leak detection, low maintenance, fail-to-safe detection and easy installation.

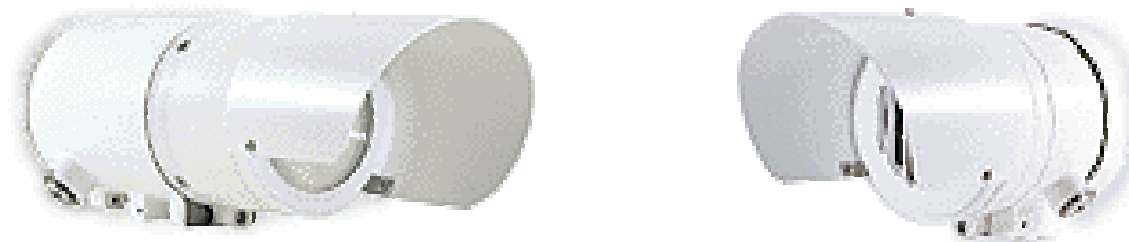

Fig. 7 Model IR5000 Open Path Infrared Gas Detection System

Unlike point gas detectors, open path IR detectors do not pinpoint the location of a leak since the leak can occur anywhere along the optical path. The gas concentration output for open path detectors is therefore expressed in ppm.meters or LEL.meters since only the product of the average gas concentration and gas cloud length can be calculated. This means that a small dense cloud of hydrocarbon gas could give the same output as a large dispersed cloud if the integral of the gas concentration over the path length were the same. A unique feature of the Model IR5000 is a dual range, ppm.m for small hydrocarbon leaks and LEL.m for more catastrophic leaks, with the ability to switch between ranges as required.

Open path systems are particularly useful in those situations where a gas release has been dispersed by wind or natural diffusion. The gas can still be detected, even though its point concentration may have fallen below normal alarm settings for point detectors. If a gas leak creates a cloud, it generally has the following characteristics:

- The highest gas concentration of a cloud is at the source and it decreases in concentration towards the edges.
- The shape of the gas cloud is elongated or has an irregular pattern, depending upon air currents.
- In outdoor environments gas clouds dissipate more quickly and can have very low gas concentrations (see Figure 8).

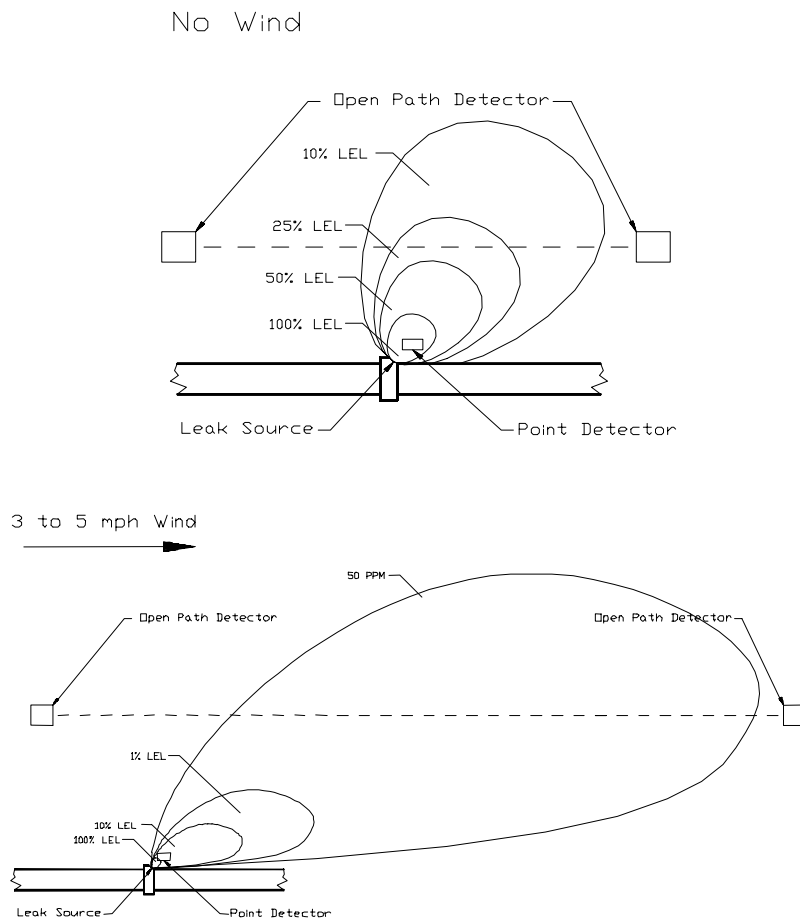

Fig. 8 IR5000 and evolution of a leaking gas cloud

Open path systems have the advantage of being able to cover large open areas, a line of several potential leak sources such as a row of valves or pumps, and also for perimeter monitoring of leaks. A mirror can also be used to deflect the optical beam around a corner to the receiver. Whereas hydrocarbon detection systems use relatively inexpensive components and are used to monitor larger leaks, more expensive diode laser based systems are currently available that can monitor toxic gases such as hydrogen fluoride and hydrogen sulfide at low ppm/meter levels.

However, open path gas detection is not an all-encompassing answer to gas detection, but offers another solution to gas detection challenges and should be used in combination with point gas detection due to the limitations in targeting specific locations of gas leaks. Fig. 9 shows a typical installation that uses both IR2100 point detectors as well as IR5000 open path detectors to provide adequate gas leak detection coverage. Open path detectors are used outdoors to monitor loading and unloading from rail cars, and to monitor storage tanks. Point detectors are used indoors and at potential leak sites outdoors such as pumps and tank farms.

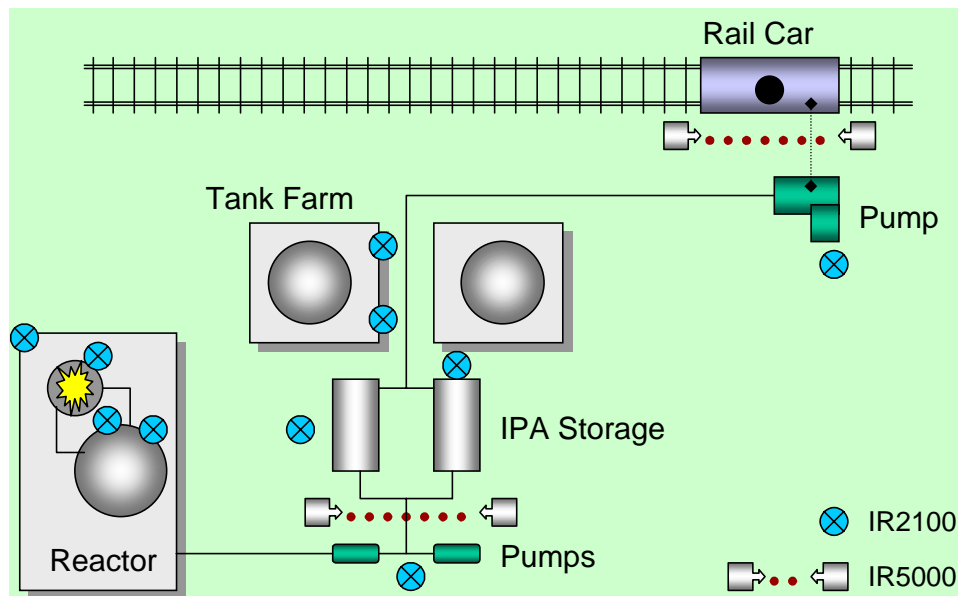

Fig. 9 Typical Installation for IR2100/IR5000 Point and Open Path Gas Detectors

For further information, please contact the authors at:

General Monitors

26776 Simpatica Circle

Lake Forest, CA 92630

Phone: 949-581-4464

Fax: 949-581-1151

Email: shafiqk@generalmonitors.com

shankarb@generalmonitors.com